



Boat Guard 20A Relay

An End to Boat Switch Problems

Barantech's Boat Guard 20A Relay: the answer to boat switch problems. This piezo touch switch retrofits 22mm pushbutton switches with ease, featuring interchangeable relay modules for maximum flexibility.

Key Characteristics

- **Unmatched Durability:** Stainless steel or anodized aluminum housing options for an ultra-rugged design.
- **Effortless Installation:** Snap-on relay module for quick setup.
- **Vivid Illumination:** Tri-color RGB ring illumination for captivating visual appearance.
- **Reliable and Sealed:** No moving parts, completely sealed against the elements.
- **Enhanced Touch Activation:** Operate by hand, gloves or tools with touch-activated functionality.
- **Built for the Elements:** Unaffected by water, salt accumulation, UV rays, ice, humidity, extreme temperatures as well as shocks and vibrations.

Electrical Data

Switch Function	On/Off toggle
Switch Voltage	9-13V DC
Relay Voltage/Current	250V AC@20A, free polarity
RGB LEDs Current Consumption	12V@30mA

Mechanical Data

Housing Materials	Stainless Steel or Aluminum
Relay Box Materials	Polycarbonate
Actuation Force	3-5 N
Connection	Switch: 22 AWG, Length 300mm Relay: tabs

Environmental Data

Operating Temperature	-20°C to +75°C
Storage Temperature	-40°C to +85°C
Random Vibration	MIL-STD-810G: 08 Method:514.6, Watercraft Category: 21, Marine Vehicles
IP Protection	Front switch side - IP68



Electrical Connection

Manual RGB illumination:

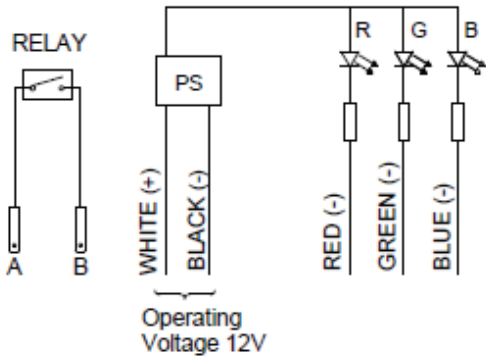

Auto internal control - two colors illumination:

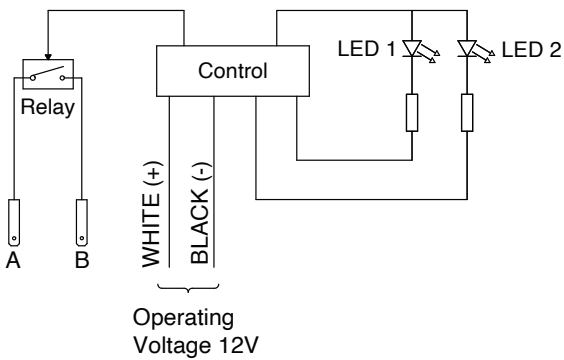

Color Options

LED 2 - *OFF* State	LED 1 - *ON* State
R	G
	B
G	R
	B
B	R
	G

Auto internal control - one color illumination:

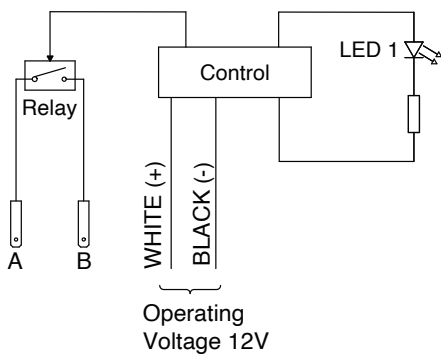

Color Options

LED 2 - *OFF* State	LED 1 - *ON* State
None	R
	G
	B

Mechanical Drawing

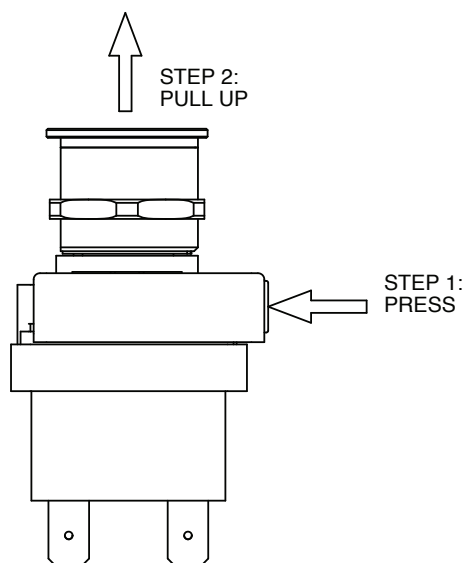
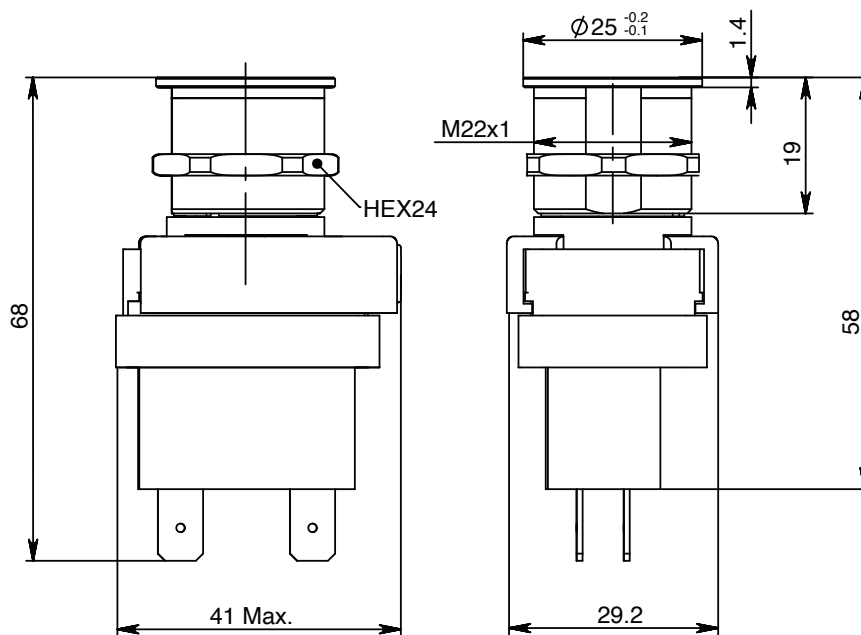

*The specifications, descriptions and illustrations indicated in this document are based on current information. All content is subject to modifications and amendments. Users should evaluate the suitability and test each product selected for their own applications.